

## Further features

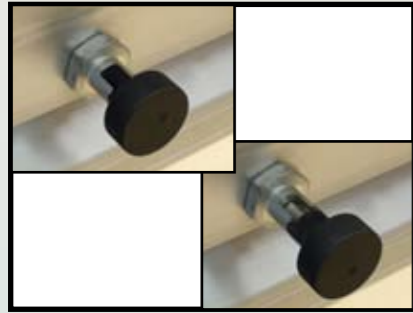

Simple indexed table-lock system

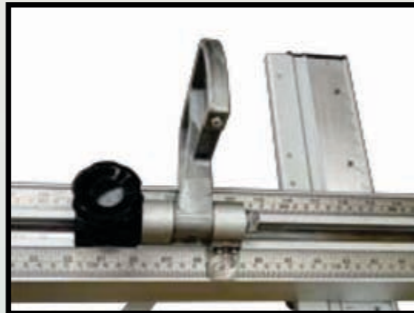

Flip-over stops, with curved base  
Slide a panel underneath without re-positioning  
Two adjustable measuring tapes  
Angled for ease-of-reading

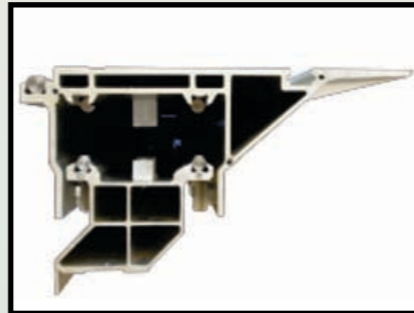

Dual-roller sliding carriage system  
Smooth running  
Minimal maintenance

## Technical Specifications - MJK113B

Main table dimensions	1190mm x 695mm	Main blade	Electronic rise & fall
Rear table extension dimensions	665mm x 695mm	Maximum cutting depth at 90°	95mm
Side table extension dimensions	1190mm x 805mm	Saw blade diameter min / max	300mm / 350mm
Cross-cut table dimensions	1460mm x 595mm	Saw blade speed	4200 / 5500 rpm
Sliding table dimensions	420mm x 3200mm	Saw blade tilt	0 - 45° with electronic control
Sliding table stroke	3200mm	Bore	30mm
Rip fence	Touch screen control	Scoring blade	Electronic rise & fall
Rip fence capacity	1300mm	Scoring blade depth of cut	0 - 5mm
Main blade power	5.5kW (7.5hp)	Scoring blade diameter	120mm
Scoring blade power	.75kW (1hp)	Scoring saw speed	8000rpm
Saw unit outlet extraction	120mm	Scoring blade tilt	0 - 45° with main blade
Overhead guard outlet extraction	120mm	Bore	22mm
Net Weight (approx)	980kg		

\* The manufacturer reserves the right to amend specifications without notice

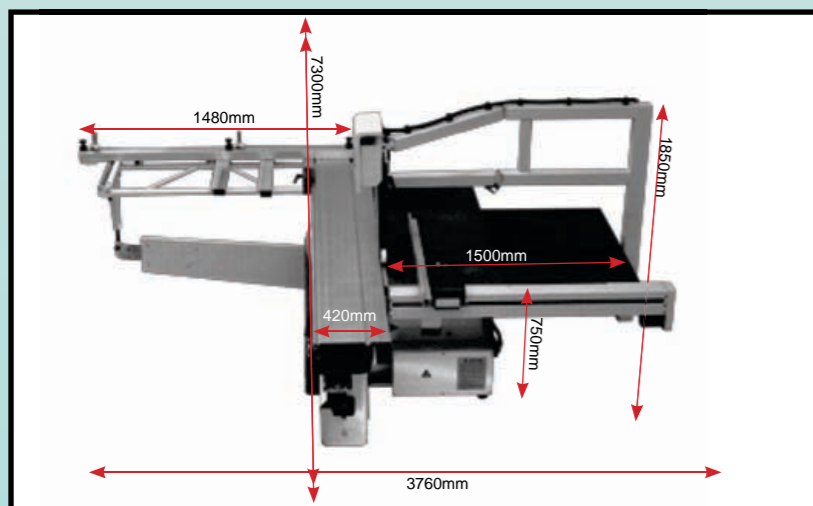

Available in NZ exclusively from:

W & R Jack Ltd.  
19 Allens Rd, East Tamaki  
159 Ferry Road, Christchurch

Sales 0800 332 288  
Spares 0800 502 000  
Service 0800 522 577

[www.jacks.co.nz](http://www.jacks.co.nz)



# Panelectric

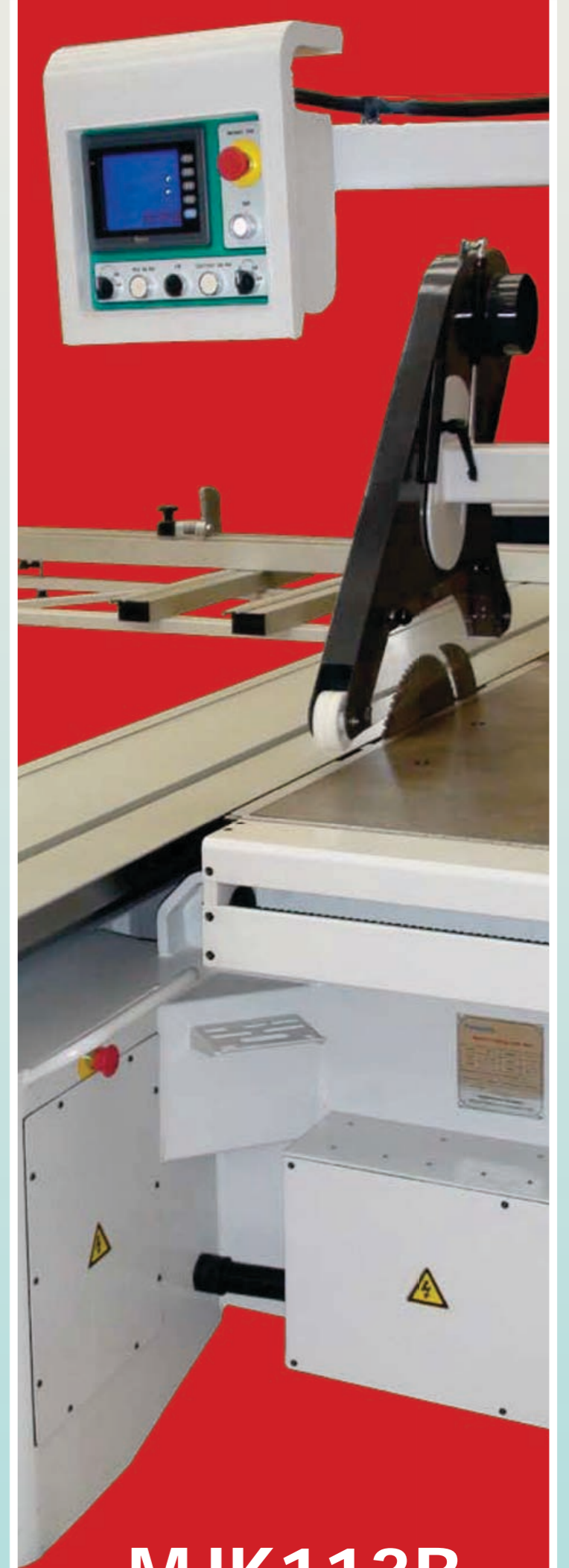

## MJK113B

# Panetric MJK113B - more cut for your buck

Powered rip-fence = at least 30% time saving!



## Features



### CNC Control

- Programmable rip fence
- Touch-screen control
- Powered rise & fall
- Powered tilt
- Scorer powered rise & fall



### Unbeatable Accuracy

- Servo-driven 25mm ball screw
- Unparalleled rip-fence accuracy



### Advanced Technology

- Powered ripfence
- Linear Guide system out to 1300mm
- Safety zone



### Quick changover and set-up

- Crosscut fence moveable from 90° to 45°
- Positive pin locking at 5° intervals
- Clampable at any angle in between

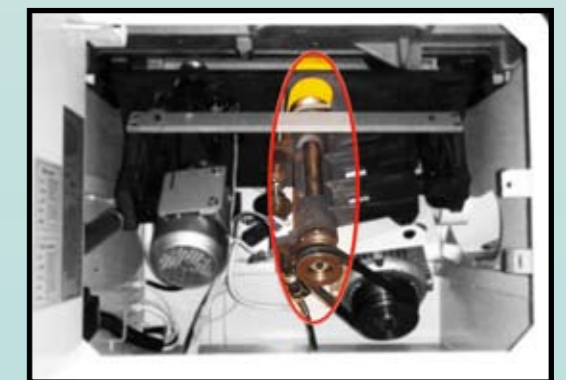

### Heavy-duty construction

- 400mm spindle shaft = more precision at the sawblade
- Electro-mechanical brake
- Automatic Star Delta start-up